

TOPP & CO.

GREAT BRITAIN

Exquisite Architectural Metalwork

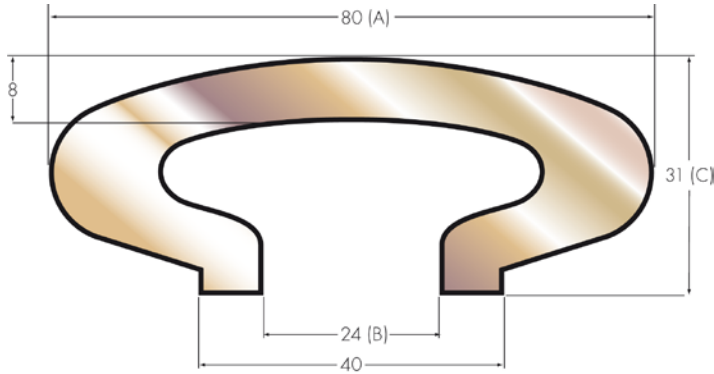

Shown actual size
mm dimensions

Bronze Handrail MBH4

Length: 5 metre (16ft)
Weight per length: 49kg
Price per length: On Application

Tolerances

A ± 0.60
B ± 0.42
C ± 0.50

Supplied unfinished. If we can help with forming the ends of your runs, curving to suit your installation requirements, etc. please let us know.

Fabrication Properties	Excellent hot working, temperature range	680° - 730° C
	Less suitable for cold working, max reduction	15%
	Machining, as percentage of CuZn39Pb3, (100%)	Fair, 40%
	Annealing temperature range	550° - 650° C
	Stress relieving temperature range	280° - 350° C
	Soldering	Good
	Brazing	Good
	Oxy-acetylene welding	Excellent
	Gas-shielded arc welding	Excellent
	Resistance welding, butt	Fair
Resistance welding, seam and spot	Not recommended	

Working characteristics

Manganese bronze handrail can be formed either cold or hot, depending on the complexity of the shape. A 1% iron content makes achieving tight radii easy. But on really tight radii, the handrail will still stretch on the outside and ripple on the inside.

Manganese bronze can be brazed, TIG welded or silver soldered. If you decide to braze or TIG weld, we would recommend you use the same material in brazing or welding rods. Because there is zinc in the handrail, if you braze or TIG weld you will always get a slight difference in colour between the weld and the rest of the handrail. The best option is to use silver solder. Make a butt joint as tight as possible before soldering it. When the soldering is cleaned you will only see a very tiny line on the joint.

Polishing and patinating

Manganese bronze handrails polish exactly the same as any other handrail.

If you want to patinate the manganese bronze handrail, we suggest using a chemical called Curator Antique Fluid. You can get different types of colouring - black, brown and bronze.

When patination is applied, wait for the desired finish, then you need to stop the oxidation by washing the handrail with clean water. You will have to let it dry and make sure there is no moisture. Then you have to seal the patination with Jade oil and a lacquer. Be careful not to use oil with strong solvent in it as it will remove the patination.

If you need the chemical composition for this handrail please ask.

TOPP & CO.

GREAT BRITAIN

Unit 5, The Airfield • Tholthorpe • North Yorkshire • YO61 1ST • United Kingdom
+44 (0)1347 833173 • enquiry@toppandco.com • www.toppandco.com

Updated May 2017